

HDM's EQ48 Battery Equalizer is a bi-directional circuit which balances the voltage between two or more individual batteries connected in series during charge, discharge, and idle periods. EQ48 prevents severe under and over voltage, common in series connections, which can compromise the performance, reliability, and life of your battery system. It will also equalize batteries which are out-of-balance due to 12-volt loads (i.e. vehicle lights) being connected to a single battery in a 48-volt battery pack. Equalized batteries are able to receive a full, clean charge, increasing battery pack power, capacity, and life, therefore supporting your mission much better.



Technical Specifications

Electrical	
Nominal Battery Voltage	12V _{DC}
Operating Voltage Range	10.5 ~ 16.5V _{DC}
Maximum Equalization Current (I _{EQ})	5A _{DC} ¹
Current Limit	< max I _{EQ}
Quiescent Current Draw	< 20mA _{DC}
Low Voltage Shutdown	10.5V _{DC}
Overvoltage Shutdown	16.5V _{DC}
Differential Voltage Auto Shutdown	> 2.5V _{DC}
Operating Modes	Charge; Discharge; Idling
LED Status Indicator	
Steady Green	Normal Equalization Mode
Blink Green/Orange	Equalization Mode with Diagnostic Code
Steady Red	Auto Shutdown ²
General	
Operating Temperature	-40 ~ +50°C
Storage Temperature	-40 ~ +85°C
Connections	24" 12AWG with 3/8" Stud Ring Terminal
Fuse	5A AGC
Dimensions (LxWxH")	7.25 x 2.34 x 1.1
Weight	1.2 lbs
Warranty	1 year

Specifications typical at 25°C unless otherwise stated and are subject to change without notice.

¹ Maximum pulse current during equalization mode.

² EQ48 will auto-recover when parameters are within operating limits.

MODE	LED	LED INDICATOR	CONDITION
NORMAL		STEADY GREEN	EQUALIZATION
EQUALIZING WITH DIAGNOSTIC CODE		BLINK GREEN/ORANGE 4.5 sec GREEN 1x 0.1 sec ORANGE = 1 st Battery 2x 0.1 sec ORANGE = 2 nd Battery 3x 0.1 sec ORANGE = 3 rd Battery 4x 0.1 sec ORANGE = 4 th Battery	LOW OR OVER VOLTAGE Module will auto-recover and resume equalization mode when parameters are within operating limits. LED will continue to blink until module is manually reset.
AUTO SHUTDOWN		STEADY RED	LOW, OVER, OR DIFFERENTIAL VOLTAGE Module will auto-shutdown and auto-recover when parameters are within operating limits.



All dimensions in inches unless otherwise specified.

PB-EQ48 20110125-1200

Industry-Leading Features

- ♦ Patent-Pending Equalization Technology which Reduces Size, Costs, and Weight
- ♦ Equalizes up to 4 batteries (4 x 12V_{DC}) in a Series String
- ♦ Easy Installation and Mounting
- ♦ Appropriate for Sealed, AGM, and GEL Batteries
- ♦ Extends Battery Life and Run Time
- ♦ Maintenance Free

Standard Features

- ♦ Automatic Equalization during Charge, Discharge, or Idling
- ♦ Low Voltage Protection
- ♦ Overvoltage Protection
- ♦ Over Current Protection
- ♦ Reverse Polarity Protection
- ♦ Replaceable External Fuse
- ♦ Flange Mounting

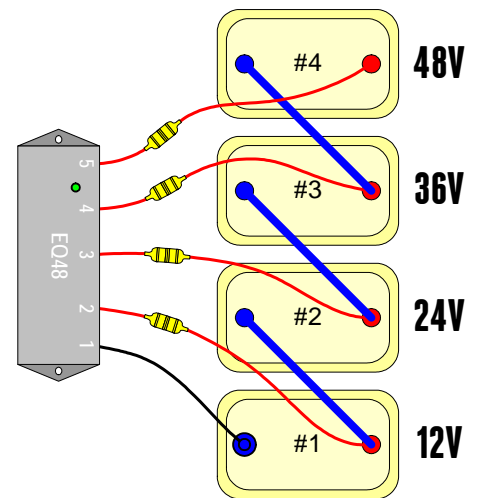

Connection Diagram for EQ48 48V Battery Bank

Model	Description
EQ24	24V Battery Equalizer
EQ36	36V Battery Equalizer
EQ48	48V Battery Equalizer

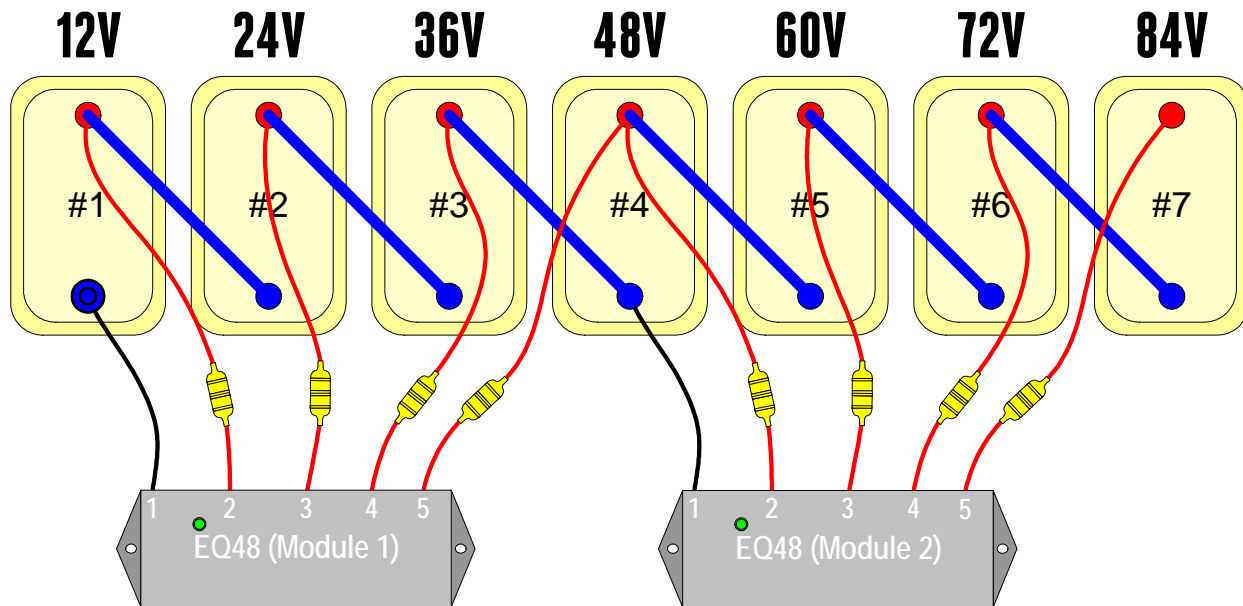

⚠ CAUTION: Always disconnect or turn OFF all external charging sources and/or DC loads before installing or removing the EQ48 module.

⚠ CAUTION: When connecting the EQ48 module, always follow the connection sequence or will damage module and/or void product warranty.

Battery Equalizer Installation Instructions

1. Install battery equalizer in a location close to the main battery bank. Avoid installing in a location which may be exposed to high temperature such as near the engine.
2. Connect per connection diagram starting from the negative terminal of the **1st** battery in the series connected string.
 - a) Connect Wire1 (Black) of Module1 to the negative terminal of the 1st battery (#1).
 - b) Connect Wire2 (Red) of Module1 to the positive terminal of the 1st battery (#1).
 - c) Connect Wire3 (Red) of Module1 to the positive terminal of the 2nd battery (#2).
 - d) Connect Wire4 (Red) of Module1 to the positive terminal of the 3rd to the last battery (#3).
 - e) Connect Wire5 (Red) of Module1 to the positive terminal of the 4th to the last battery (#4).
3. Module1 LED will be solid GREEN indicating module is in equalization mode.
4. Continue to connect another module per connection diagram if applicable.

Battery Equalizer Removal Instructions

1. To remove EQ48 from the battery system, start disconnecting from the positive terminal of the **last** battery (highest voltage point).
 - a) Disconnect Wire5 (Red) of Module“n” from the positive terminal of the last battery.
 - b) Disconnect Wire4 (Red) of Module“n” from the positive terminal of the 2nd to the last battery.
 - c) Disconnect Wire3 (Red) of Module“n” from the positive terminal of the 3rd to the last battery.
 - d) Disconnect Wire2 (Red) of Module“n” from the positive terminal of the 4th to the last battery.
 - e) Disconnect Wire1 (Black) of Module“n” from the negative terminal of the 4th to the last battery.
2. Continue to disconnect another module per connection diagram if applicable.